

ROGUE®

Assembly Guide
Guide d'assemblage
Guía de ensamblaje
Montageanleitung

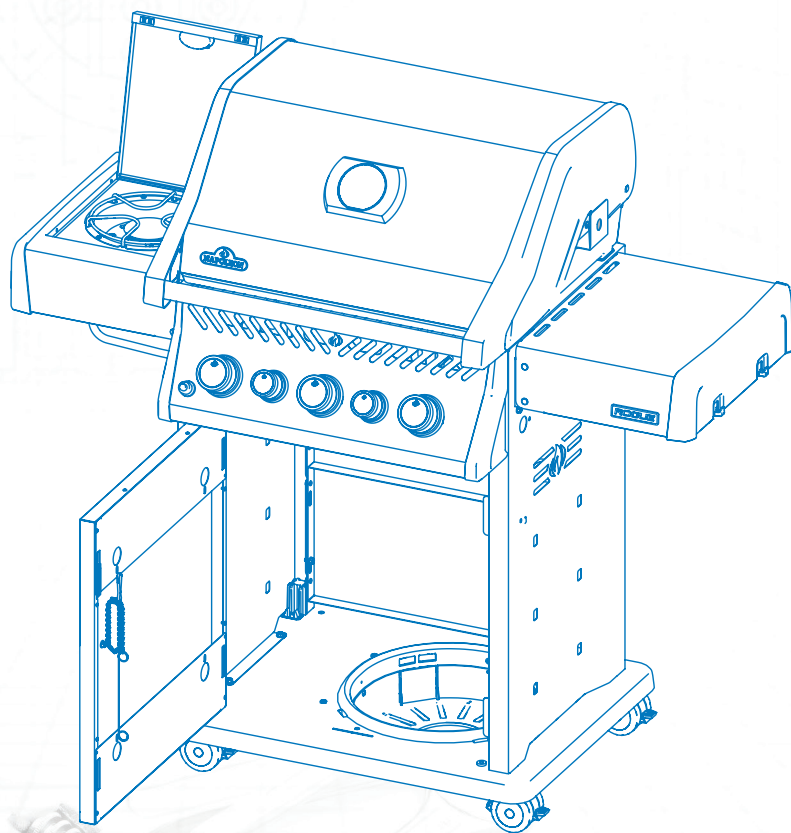

Models | Modèles | Modelos | Modelle
R365 | R425 | RB425



(EN) Assembly Guidelines | (FR) Guide de montage | (ES) Guía de instalación |
 (DK) Retningslinjer for montering | (DE) Leitlinien für die Montage |
 (FI) Kokoonpano-ohjeet | (CZ) Pokyny pro montáž | (SK) Pokyny pre montáž |
 (SI) Smernice za montažo | (SE) Monteringsanvisningar | (UA) Посібник
 з монтажу | (PL) Wytyczne dotyczące montażu | (NO) Retningslinjer for
 montering | (NL) Richtlijnen voor montage | (IT) Linee guida per l'assemblaggio
 (HR) Smjernice za sastavljanje | (GR) Οδηγίες συναρμολόγησης

- | | |
|----------------------------------|-----------------------------|
| (EN) Safety requirements | (SE) Säkerhetskrav |
| (FR) Exigences de sécurité | (UA) Вимоги безпеки |
| (ES) Requerimientos de seguridad | (PL) Wymogi bezpieczeństwa |
| (DK) Krav til sikkerhed | (NO) Sikkerhetskrav |
| (DE) Sicherheitsanforderungen | (NL) Veiligheidseisen |
| (FI) Turvallisuusvaatimukset | (IT) Requisiti di sicurezza |
| (CZ) Bezpečnostní požadavky | (HR) Sigurnosni zahtjevi |
| (SK) Bezpečnostné požiadavky | (GR) Απαιτήσεις ασφαλείας |
| (SI) Varnostne zahteve | |



- | | |
|--|--|
| (EN) Installation tools (not included) | (SE) Installationsverktyg (ingår ej) |
| (FR) Outils d'installation (non inclus) | (UA) Інструменти для встановлення
(не входять до комплекту) |
| (ES) Herramientas de instalación
(no incluidas) | (PL) Narzędzia montażowe
(brak w zestawie) |
| (DK) Installationsværktøj (medfølger ikke) | (NO) Installasjonsverktøy (ikke inkludert) |
| (DE) Montagewerkzeug (nicht enthalten) | (NL) Installatiegereedschap
(niet meegeleverd) |
| (FI) Asennustyökalut (eivät sisälly) | (IT) Strumenti di installazione (non inclusi) |
| (CZ) Instalační nářadí (není součástí
balení) | (HR) Alati za instalaciju (nisu uključeni) |
| (SK) Inštalačné náradie
(nie je súčasťou dodávky) | (GR) Εργαλεία εγκατάστασης
(δεν περιλαμβάνονται) |
| (SI) Orodja za namestitvev (niso vključena) | |



3/8
(10 mm)

3/8
(10 mm)

T30
TORX

Legend | Légende | Leyenda | Legende | Legende | Selite | Legenda
 Legenda | Legenda | Legend | Легенда | Legenda | Legende | Legende
 Legenda | Legenda | Υπόμνημα

	Warning! Avertissement ! ¡Advertencia! Advarsel! Warnung!	Varoitus! Varován! Varovanie! Opozorilo! Varning!	Обережно! Ostrzeżenie! Advarsel! Waarschuwing! Attenzione!	Υποζορευνη! Προειδοποίηση!
	Caution! Attention ! ¡Precaución! Forsigtig! Vorsicht!	Varoitus! Pozor! Pozor! Varning! Обережно!	Uwaga! Forsiktig! Let op! Attenzione! Oprez!	Προσοχή!
	Lock Bloc Bloquear Låse	Sperren Lukko Zámek Zámok	Zaklepanje Låsa Замок Zamek	Slot Serratura Brava Κλειδαριά
	Positioning Positionnement Posicionamiento Positionering Positionierung Paikannus	Polohování Polohovanie Pozicioniranje Positionering Позиціонування Pozycjonowanie	Positionering Posizionamento Pozicioniranje Τοποθέτηση	
	Use rubber mallet Utiliser un maillet en caoutchouc Use un mazo de goma Slå med gummihammer Mit Gummihammer schlagen Käytä kumivasaraa Použijte gumovou paličku Použite gumenú paličku Uporabite gumijasto kladivo		Använd gummiklubba Використовуйте гумовий молоток Użyj gumowego młotka Bruk gummihammer Gebruik een rubberen hamer Usa un martello di gomma Koristite gumeni čekić Χρησιμοποιήστε λαστιχένια σφύρα	
	Rotate the Unit Rotation de l'appareil Rotar la unidad Drej enheden Drehen Sie das Gerät Kierrä yksikköä	Otočte jednotku Otočte jednotku Zavrtite enoto Vrid enheten Обертайте пристрій Obróć urządzenie	Roter enheten Draai de eenheid Ruotare l'unità Okrenite jedinicu Περιστρέψτε τη μονάδα	

Legend | Légende | Leyenda | Legende | Legende | Selite | Legenda |
 Legenda | Легенда | Legende | Legende | Leggenda | Legenda | Υπόμνημα



Propane Only
 Propane uniquement
 Sólo propano
 Kun propan
 Nur Propan
 Vain propaani

Pouze propan
 Iba propán
 Samo propan
 Endast propan
 Тільки пропан
 Tylko propan

Kun propan
 Alleen propaan
 Solo propano
 Samo propan
 Μόνο προπάνιο



Natural Gas
 Gaz naturel
 Gas natural
 Naturgas
 Erdgas
 Maakaasu

Zemní plyn
 Zemný plyn
 Zemeljski plin
 Naturgas
 Природний газ
 Gazu ziemnego

Naturgass
 Natuurlijk gas
 Gas naturale
 Přírodní gas
 Φυσικό αέριο



Side Burner
 Brûleur latéral
 Quemador lateral
 Sidebrænder
 Seitenbrenner
 Sivupoltin

Boční hořák
 Bočný horák
 Stranski gorilnik
 Sidobrännare
 Бічний пальник
 Palnik boczny

Sidebrenner
 Zijbrander
 Fornello laterale
 Bočni plamenik
 Πλαϊνός καυστήρας



Non - Side Burner
 Sans brûleur latéral.
 Sin quemador lateral.
 Uden - Sidebrænder
 Ohne - Seitenbrenner
 Ilman sivupoltinta

Bez bočního hořáku
 Bez bočného horáka
 Brez stranskega
 gorilnika
 Utan sidobrännare
 Без бічної конфорки

Bez palnika boczneho
 Uten sidebrenner
 Zonder zijbrander
 Senza fornello laterale
 Bez bočnog plamenika
 Χωρίς Πλαϊνό Καυστήρα



Remove film.
 Retirer le film.
 Retire la película
 Fjern film
 Folie entfernen
 Poista kalvo

Odstraňte fólii
 Odstráňte film
 Odstranite film
 Ta bort filmen
 Зняти плівку
 Usuń folię

Fjern filmen
 Verwijder folie
 Rimuovere la
 pellicola
 Uklonite film
 Αφαιρέστε το φιλμ



Caution Head Injury
 Attention blessure à la tête
 Atención lesión craneal
 Forsigtig Hovedskade
 Vorsicht Kopfverletzung
 Varoitus Pään vamma

Pozor Poranění hlavy
 Pozor Poranenie hlavy
 Pozor Poškodba glave
 Varning Huvudskada
 Bez bichnoyi konforky
 Uwaga, uraz głowy

Forsiktig Hodeskade
 Let op hoofdletsel
 Attenzione ferita alla testa
 Oprez Ozljeda glave
 Προσοχή Τραυματισμός
 στο κεφάλι

WELCOME TO NAPOLEON!

Congratulations on upgrading your grilling game and welcome to the **NAPOLEON** family!



Ready to assemble your new grill?



There may be visual differences between illustrations and model purchased. Remove all parts from packaging before assembling the barbecue. Set up this assembly on a solid, level and horizontal surface.

BIENVENUE À NAPOLEON!

Félicitations pour votre achat et bienvenue dans la famille **NAPOLEON**!



Prêt à assembler votre nouveau grill?



Veillez noter qu'il peut y avoir des différences entre les illustrations de ce guide et le modèle acheté. Retirez toutes les pièces de leur emballage avant de commencer. Veillez à assembler votre grill sur une surface plane et solide.

¡BIENVENIDO A NAPOLEON!

¡Felicidades por mejorar tu juego de parrilla y bienvenido a la familia **NAPOLEON**!



¿Listo para ensamblar tu nueva parrilla?



Tenga en consideración que puede haber diferencias entre las ilustraciones en esta guía y el modelo adquirido. Remueva todas las piezas de sus empaques antes de comenzar. Asegúrese de ensamblar la parrilla en una superficie plana y sólida.

VELKOMMEN TIL NAPOLEON!

Tillykke med, at du har opgraderet dit grillspil, og velkommen til **NAPOLEON**-familien!



Er du klar til at samle din nye grill?



Der kan være visuelle forskelle mellem illustrationer og den købte model. Tag alle dele ud af emballagen, før du samler grillen. Stil grillen op på en solid, plan og vandret overflade.

WILLKOMMEN BEI NAPOLEON!

Herzlichen Glückwunsch zur Aufrüstung Ihres Grills und willkommen in der **NAPOLEON**-Familie!



Sind Sie bereit, Ihren neuen Grill zusammenzubauen?



Es kann optische Unterschiede zwischen den Abbildungen und dem gekauften Modell geben. Nehmen Sie vor dem Zusammenbau des Grills alle Teile aus der Verpackung. Stellen Sie die Baugruppe auf einer festen, ebenen und horizontalen Fläche auf.

TERVETULOA NAPOLEONIIN!

Onnittelut grillauspelisi päivittämisestä ja tervetuloa **NAPOLEON**-perheeseen!



Oletko valmis kokoamaan uuden grillisi?



Kuvissa ja ostetussa mallissa voi olla visuaalisia eroja. Poista kaikki osat pakkauksesta ennen grillin kokoamista. Aseta tämä kokoonpano kiinteälle, tasaiselle ja vaakasuoralle alustalle.

VÍTEJTE V NAPOLEONU!

Blahopřejeme vám k vylepšení vaší grilovací hry a vítáme vás v rodině **NAPOLEON!**



Jste připraveni sestavit svůj nový gril?



Mezi ilustracemi a zakoupeným modelem mohou být vizuální rozdíly. Před sestavením grilu vyjměte všechny díly z obalu. Tuto sestavu postavte na pevný, rovný a vodorovný povrch.

VITAJTE V NAPOLEONE!

Blahoželáme vám k vylepšeniu vašej grilovacej hry a vítame vás v rodine **NAPOLEON!**



Ste pripravení zostaviť svoj nový gril?



Medzi ilustráciami a zakúpeným modelom môžu byť vizuálne rozdiely. Pred zostavením grilu vyberte všetky diely z obalu. Túto zostavu postavte na pevný, rovný a vodorovný povrch.

DOBRODOŠLI V NAPOLEONU!

Čestitamo vam, da ste izboljšali svojo igro na žaru, in vas pozdravljamo v družini **NAPOLEON!**



Ste pripravljeni na montažo svojega novega žara?



Med ilustracijami in kupljenim modelom so lahko vizualne razlike. Pred sestavljanjem žara odstranite vse dele iz embalaže. Ta sklop postavite na trdno, ravno in vodoravno površino.

VÄLKOMMEN TILL NAPOLEON!

Grattis till att du har uppgraderat din grillning och välkommen till **NAPOLEON**-familjen!



Är du redo att montera din nya grill?



Det kan förekomma visuella skillnader mellan illustrationer och den modell som köpts. Ta bort alla delar från förpackningen innan du monterar grillen. Ställ upp enheten på ett stabilt, plant och horisontellt underlag.

ЛАСКАВО ПРОСИМО НА НАПОЛЕОН!

Вітаємо з оновленням вашого гриля та ласкаво просимо до сім'ї **NAPOLEON!**



Готові зібрати свій новий гриль?



Можливі візуальні відмінності між ілюстраціями та придбаною моделлю. Вийміть всі деталі з упаковки, перш ніж збирати гриль. Встановіть цю збірку на тверду, рівну і горизонтальну поверхню.

WITAMY W NAPOLEON!

Gratulujemy ulepszenia swojego grilla i witamy w rodzinie **NAPOLEON!**



Gotowy do montażu nowego grilla?



Mogą występować różnice wizualne między ilustracjami a zakupionym modelem. Przed złożeniem grilla należy wyjąć wszystkie części z opakowania. Ustaw urządzenie na solidnej, równej i poziomej powierzchni.

VELKOMMEN TIL NAPOLEON!

Gratulerer med oppgraderingen av grillspillet ditt, og velkommen til **NAPOLEON**-familien!



Er du klar til å montere din nye grill?



Det kan være visuelle forskjeller mellom illustrasjonene og modellen du har kjøpt. Ta alle delene ut av emballasjen før du monterer grillen. Sett opp denne enheten på en solid, jevn og vannrett overflate.

WELKOM BIJ NAPOLEON!

Gefeliciteerd met het upgraden van uw grill spel en welkom bij de **NAPOLEON** familie!



Klaar om uw nieuwe grill te monteren?



Er kunnen visuele verschillen zijn tussen de illustraties en het gekochte model. Haal alle onderdelen uit de verpakking voordat u de barbecue in elkaar zet. Zet dit geheel op een stevige, vlakke en horizontale ondergrond.

BENVENUTO A NAPOLEON!

Congratulazioni per aver migliorato il vostro gioco di grigliate e benvenuti nella famiglia **NAPOLEON**!



Siete pronti ad assemblare il vostro nuovo grill?



Potrebbero esserci differenze visive tra le illustrazioni e il modello acquistato. Rimuovere tutte le parti dall'imballaggio prima di assemblare il barbecue. Posizionare il gruppo su una superficie solida, piana e orizzontale.

DOBRODOŠLI U NAPOLEON!

Čestitamo na unapređenju vaše igre roštiljanja i dobrodošli u **NAPOLEON** obitelji!



Spremni za sastavljanje vašeg novog roštilja?



Može biti vizualnih razlika između ilustracija i kupljenog modela. Uklonite sve dijelove iz pakiranja prije sastavljanja roštilja. Postavite ovu montažu na čvrstu, ravnu i vodoravnu površinu.

ΚΑΛΩΣ ΗΛΘΑΤΕ ΣΤΟ NAPOLEON!

Συγχαρητήρια για την αναβάθμιση του παιχνιδιού ψησίματος και καλωσορίσατε στην οικογένεια **NAPOLEON**!



Είστε έτοιμοι να συναρμολογήσετε τη νέα σας ψησταριά;



Ενδέχεται να υπάρχουν οπτικές διαφορές μεταξύ των απεικονίσεων και του μοντέλου που αγοράσατε. Αφαιρέστε όλα τα εξαρτήματα από τη συσκευασία πριν συναρμολογήσετε το μπάρμπεκιου. Τοποθετήστε αυτό το συγκρότημα σε μια σταθερή, επίπεδη και οριζόντια επιφάνεια.

Models | Modèles | Modelos | Modelle

R365

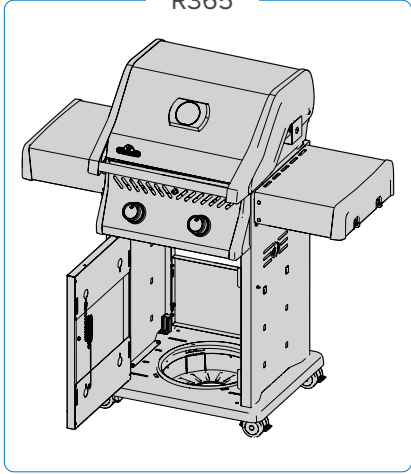

R425

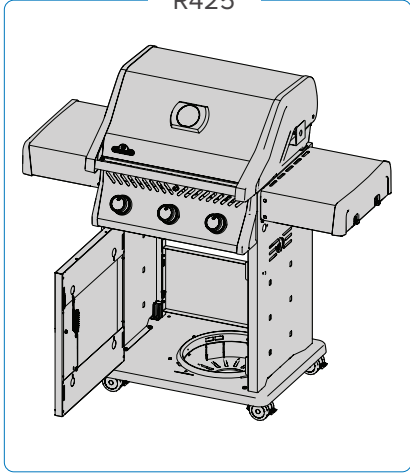

RB425

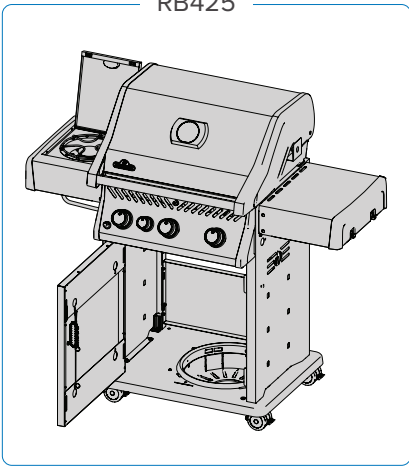

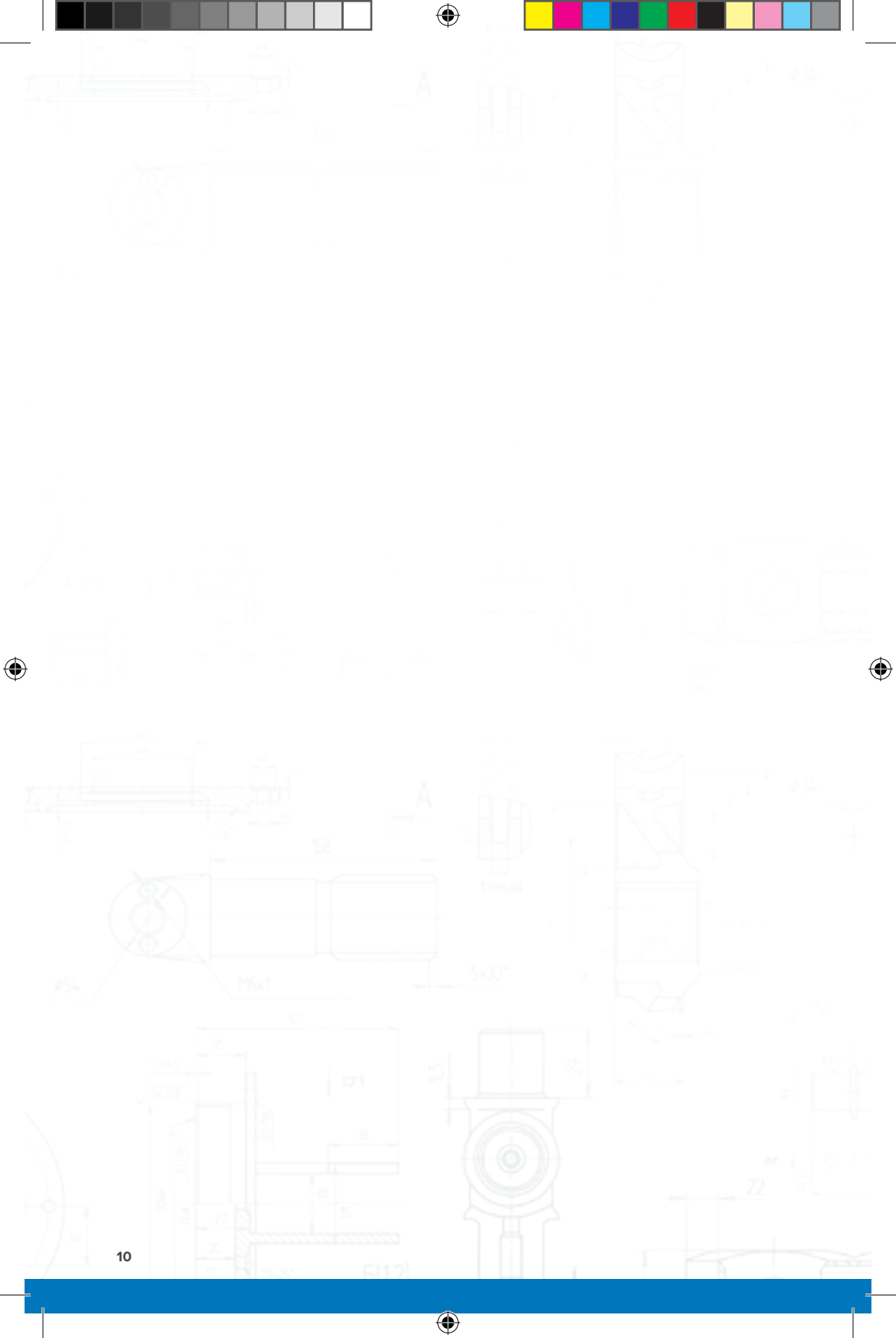



Assembly Steps
Étapes d'assemblage
Pasos para la instalación
Montageschritte



1

 x4

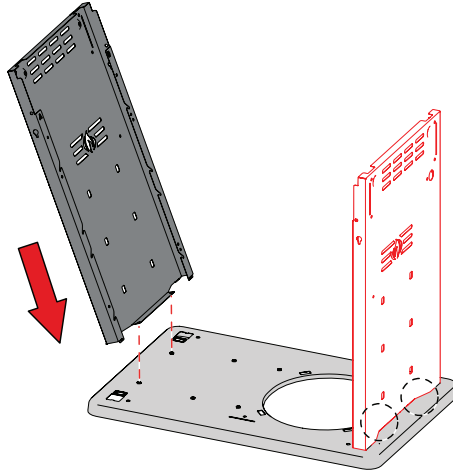
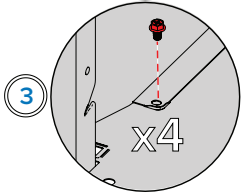
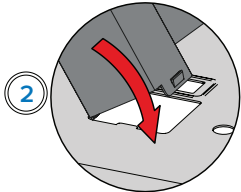
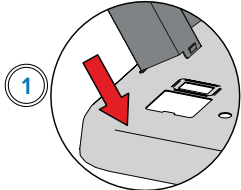

2

 x8

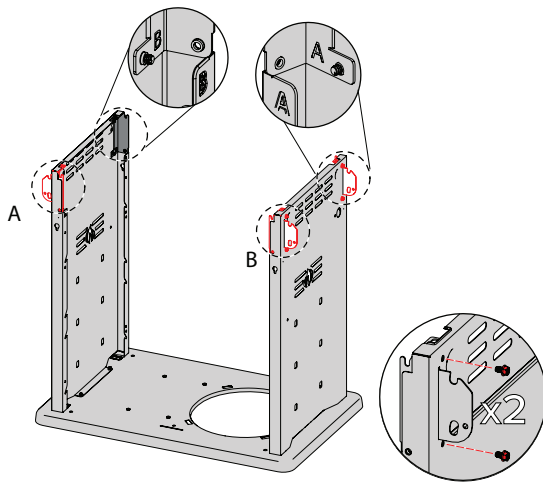
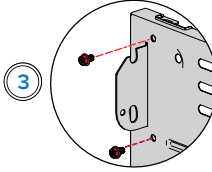
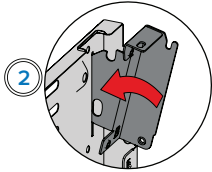
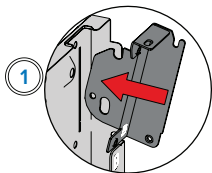

3

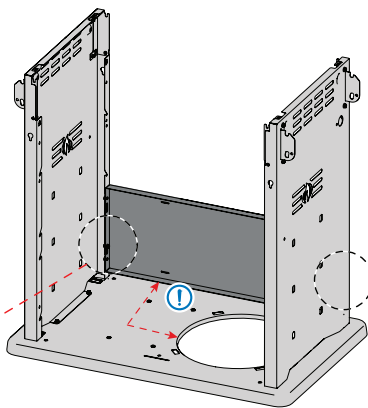
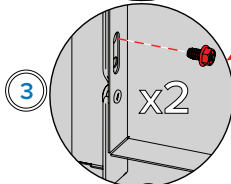
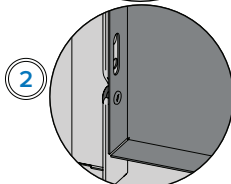
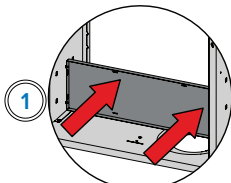

4

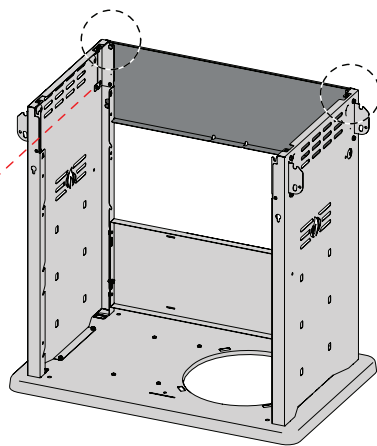
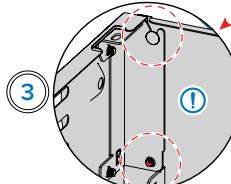
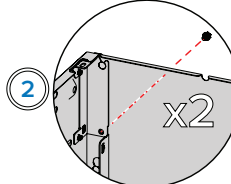
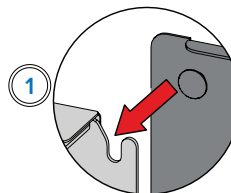

5

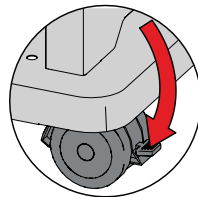
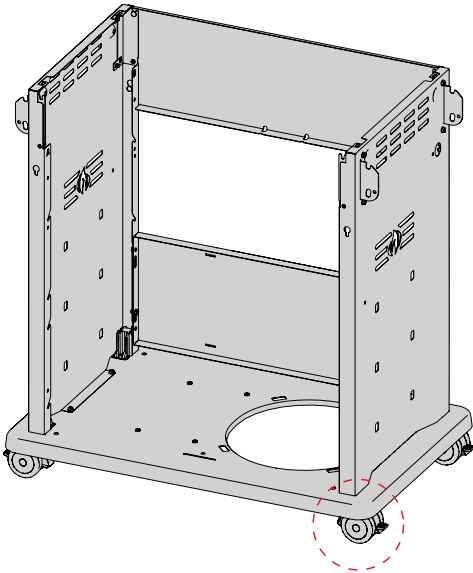
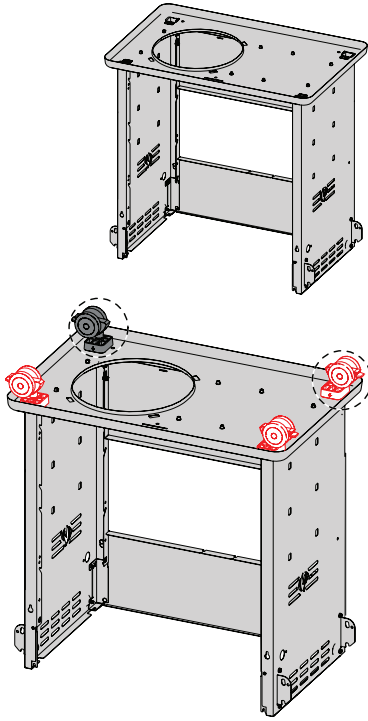
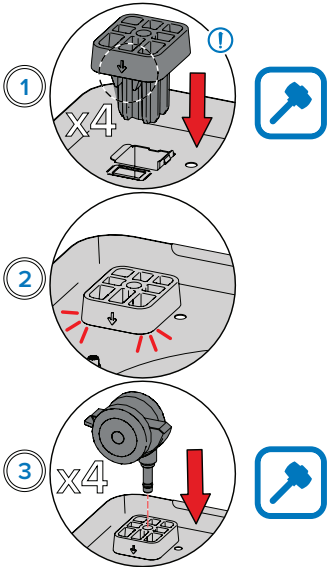

6



NON-SB



1

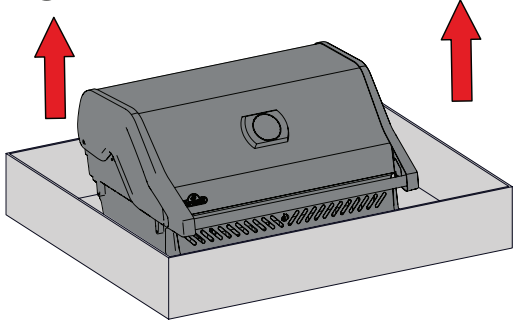

2

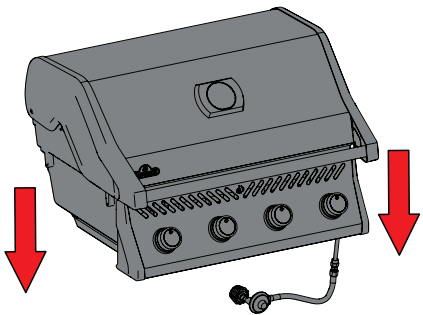

6

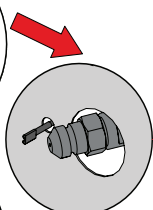
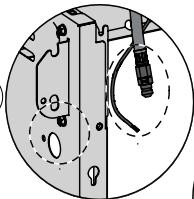

7



8

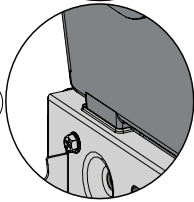

9

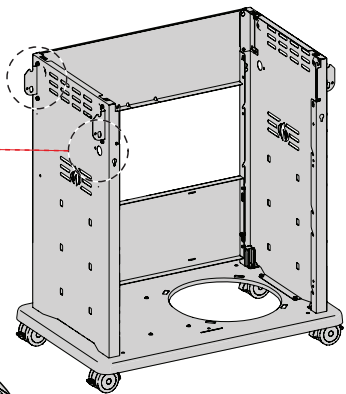
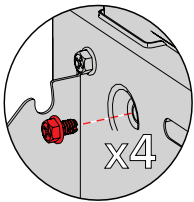

7



SB



1

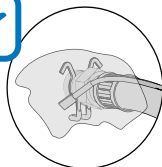

2

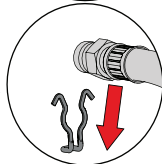

3

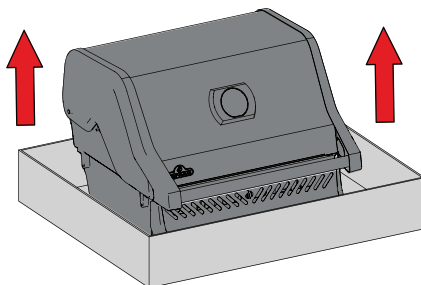

4

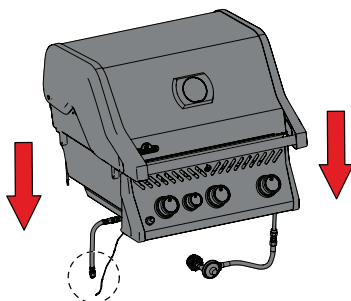

6

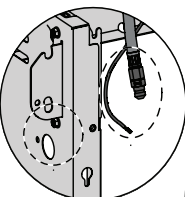

7



8

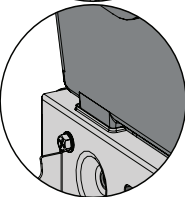

9

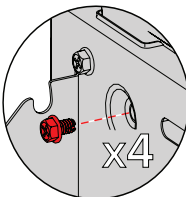

8

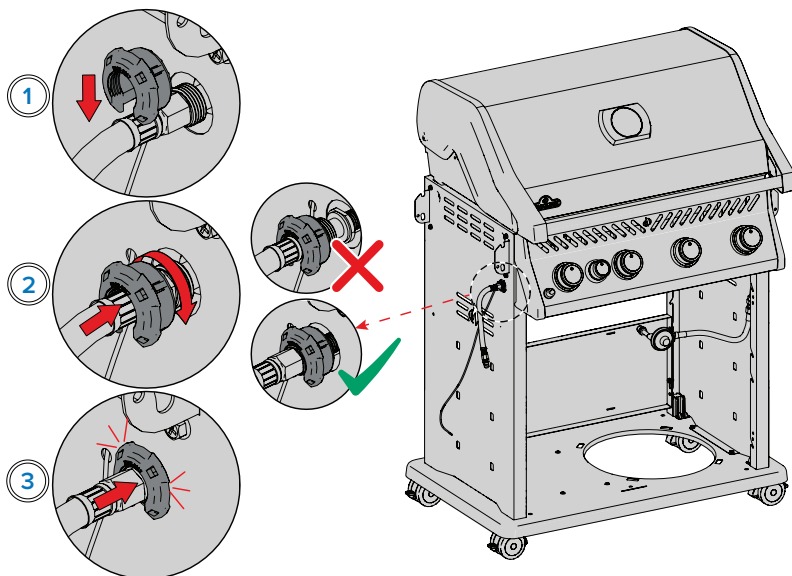

9

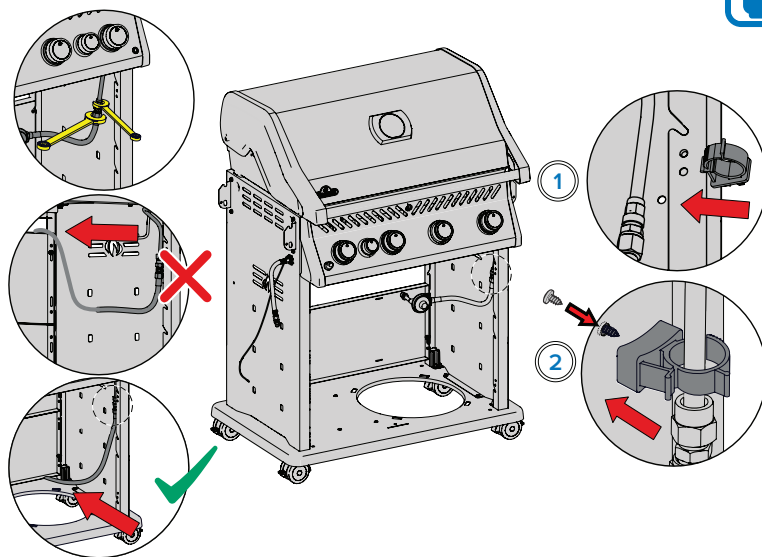

10

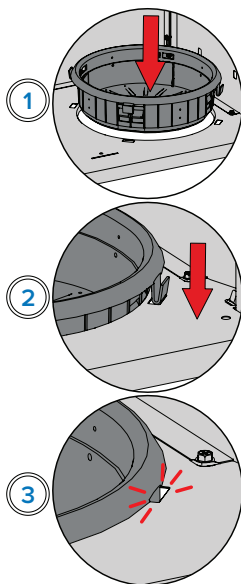
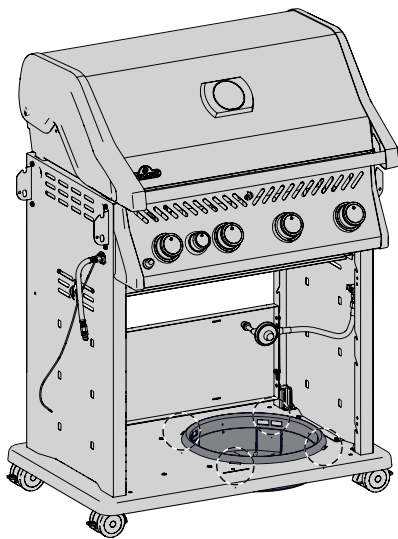

11

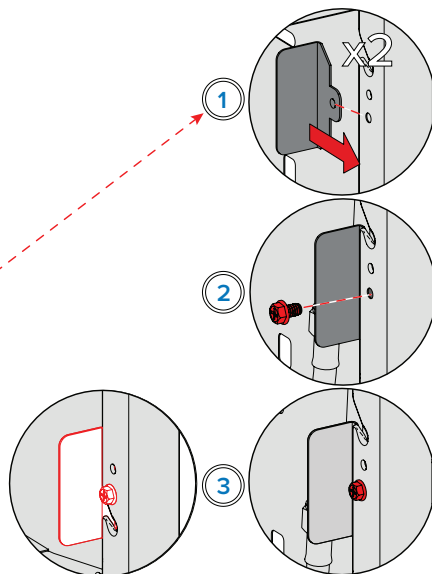
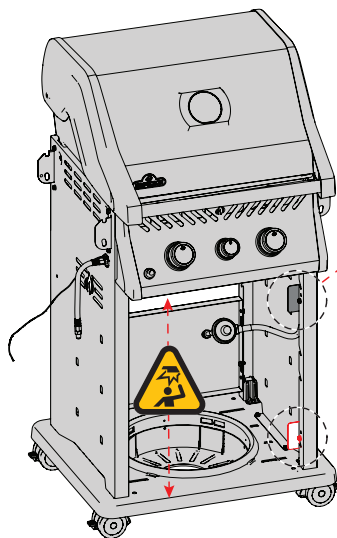



12

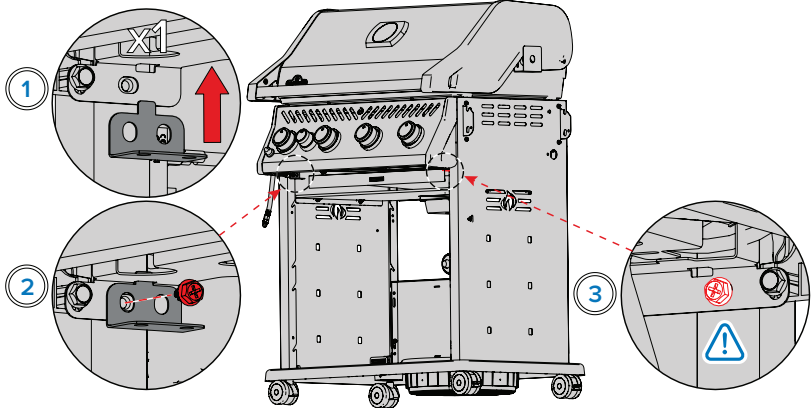

13



x4 (425)

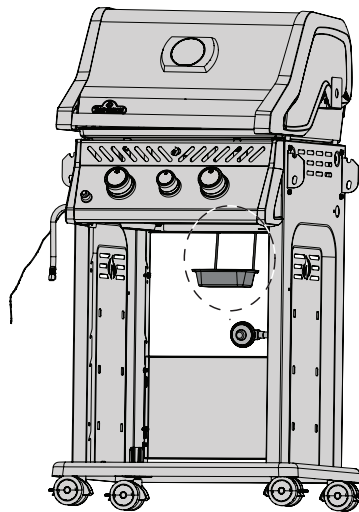
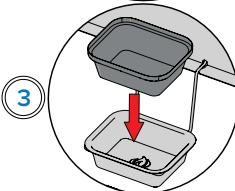
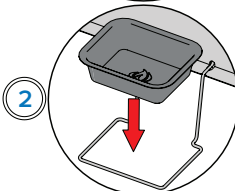
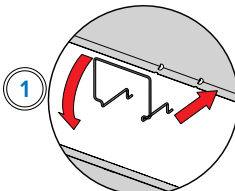
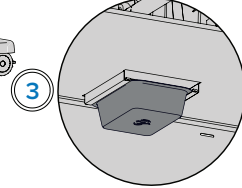
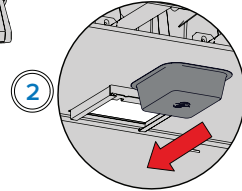
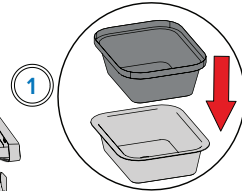
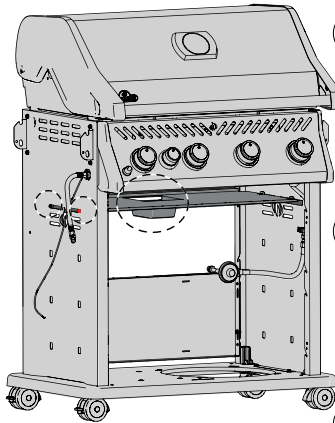
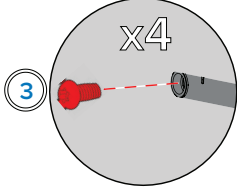
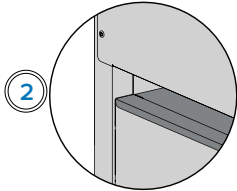
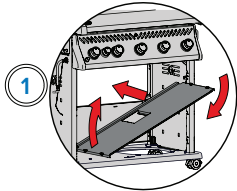



14

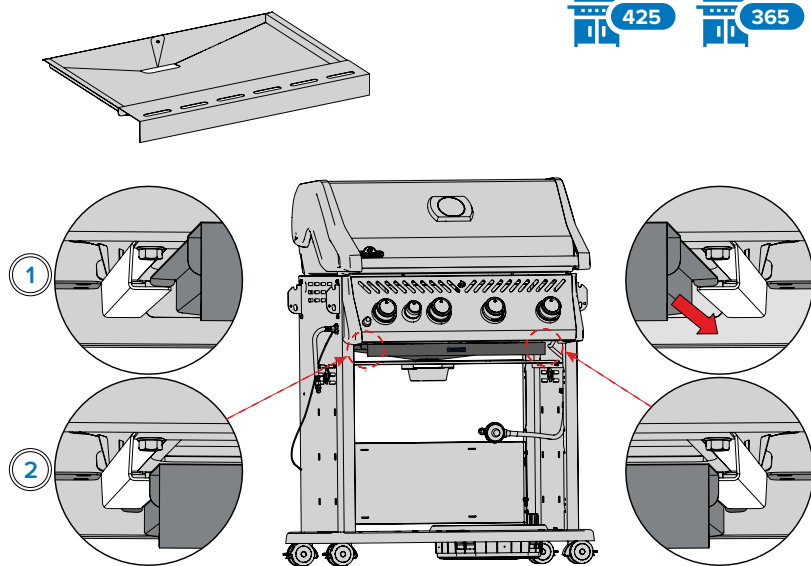

15

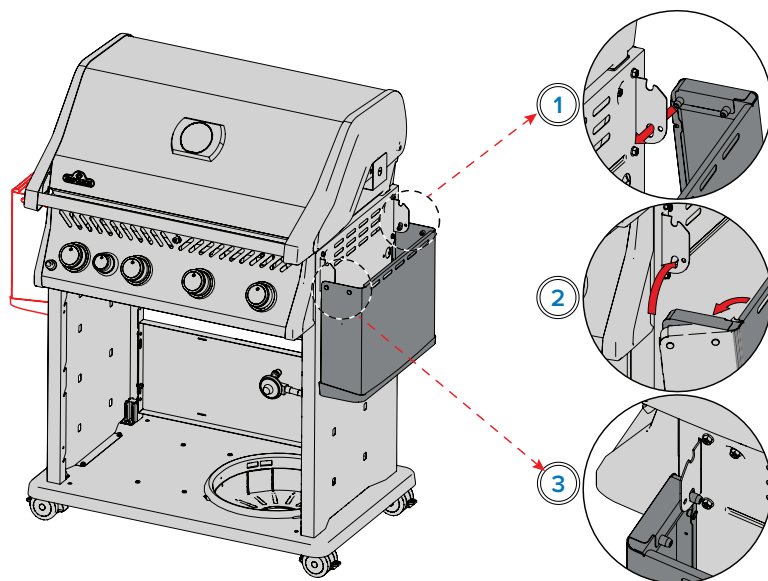

16

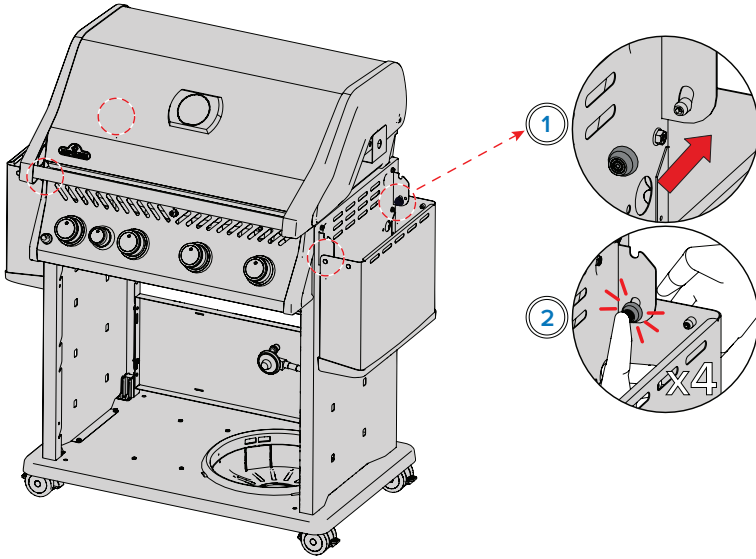

17

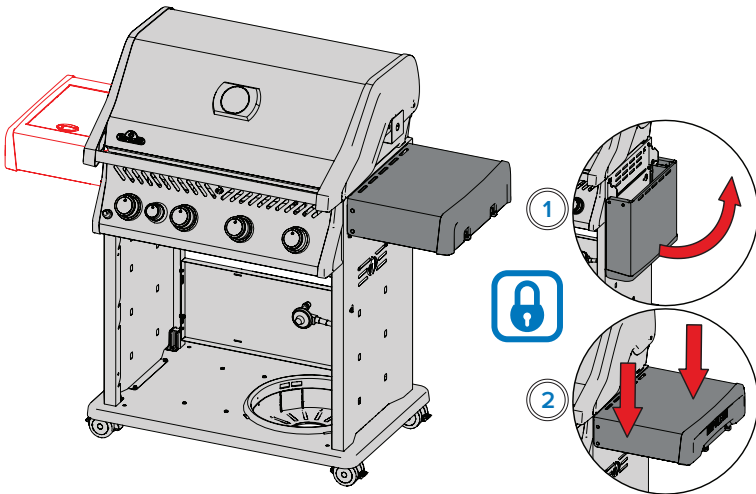

18

 x4

 x2 (425/365)

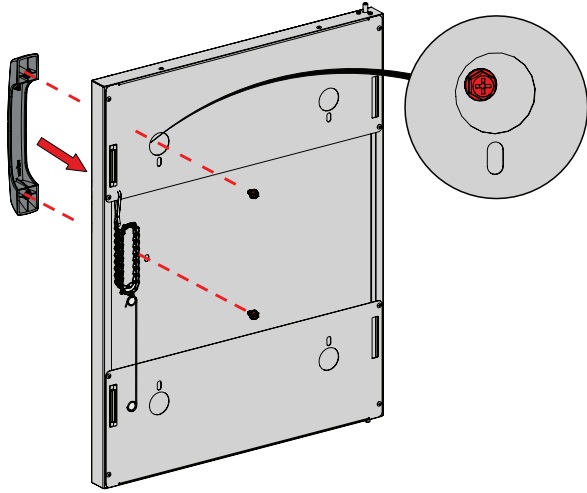

19

 x1

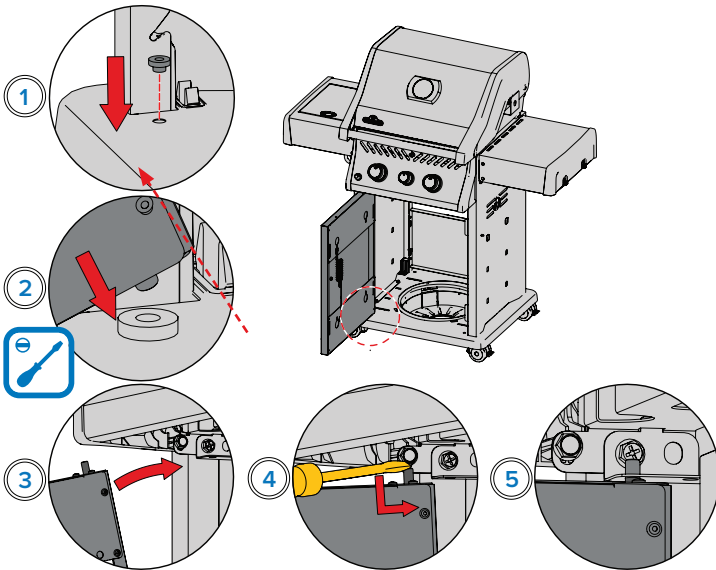

20

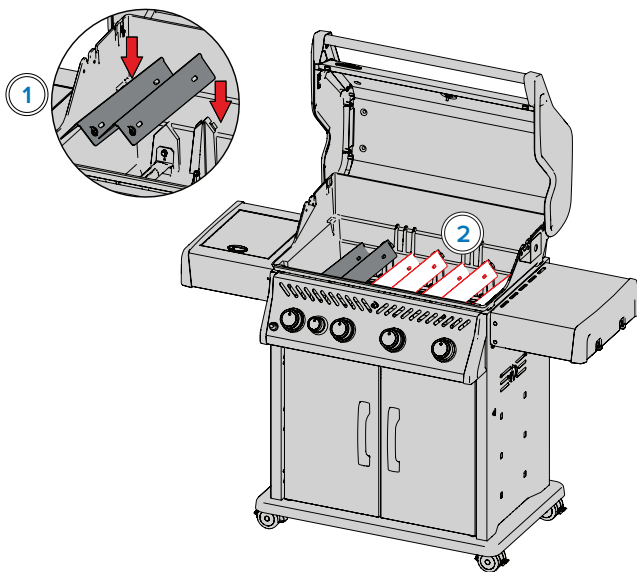

21

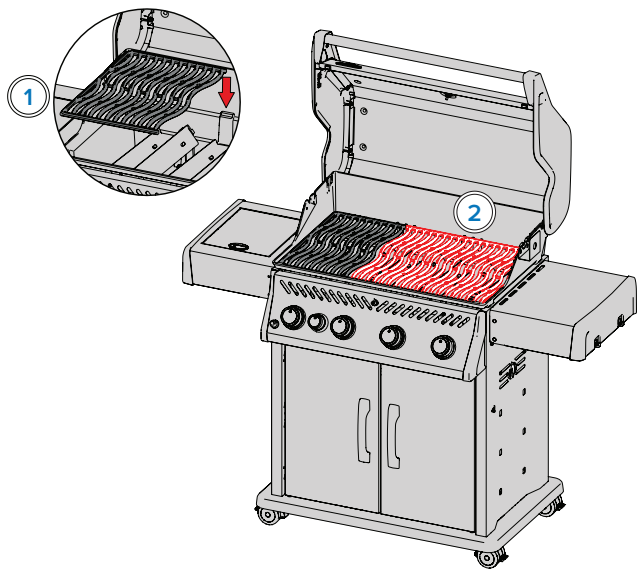

22

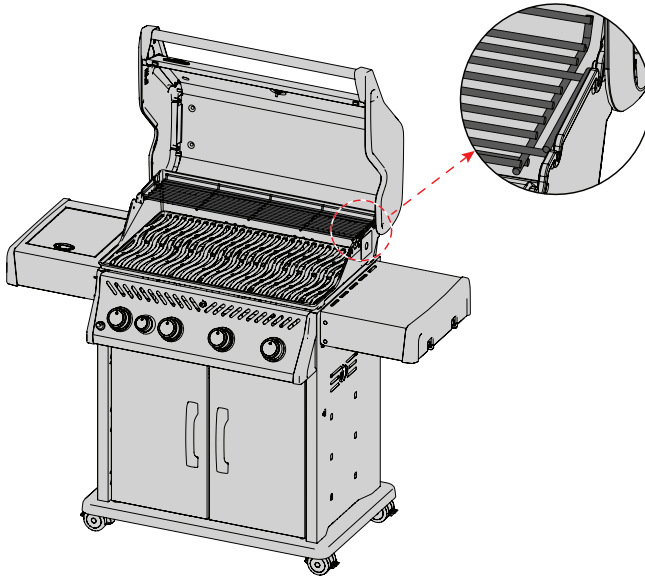

23

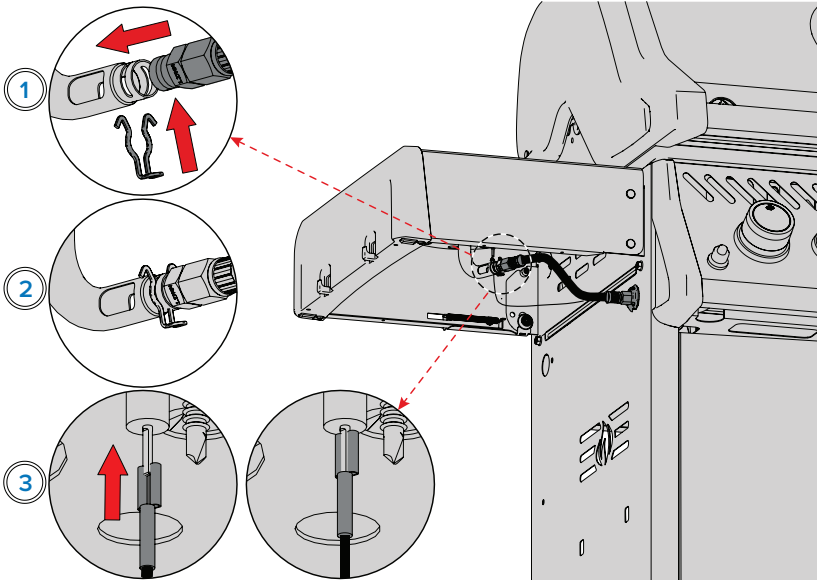

24

 NON-SB



1

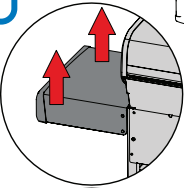

2

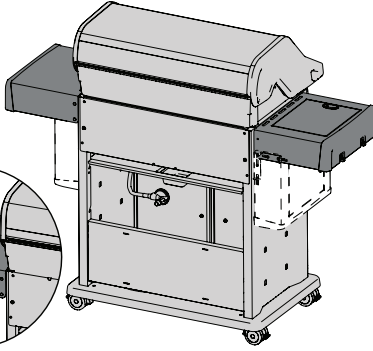
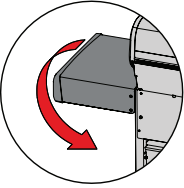

 SB

1

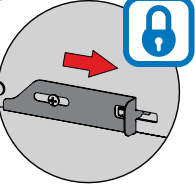

2

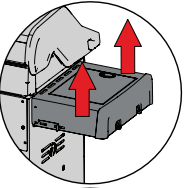

3

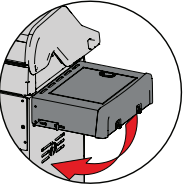

25

 SB  x1

1

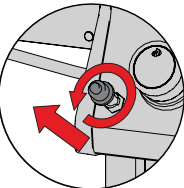

2

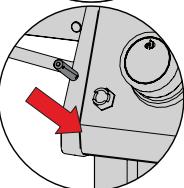

3

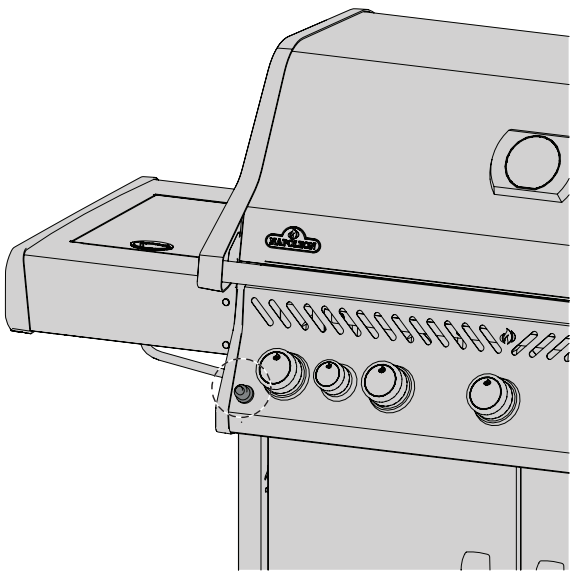
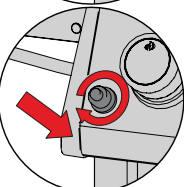

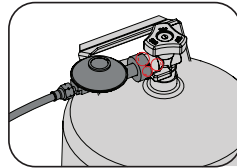
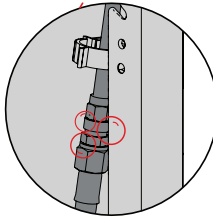
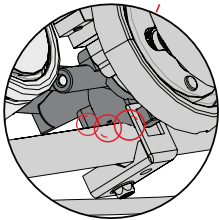
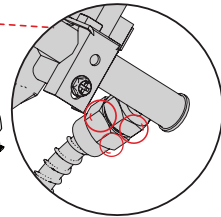
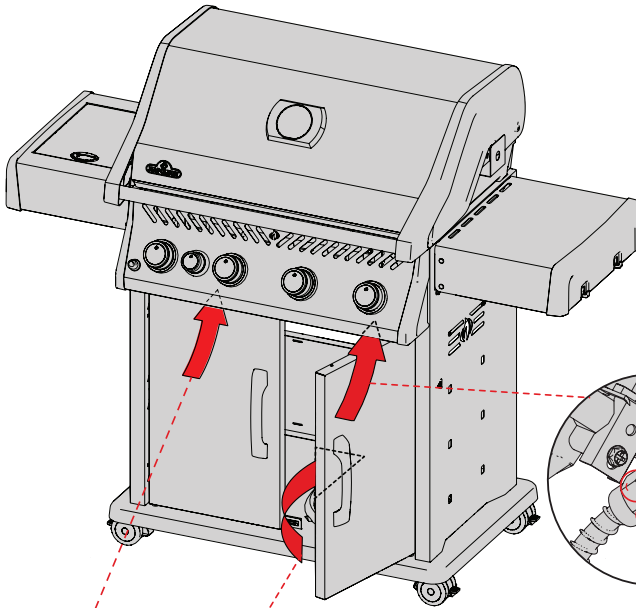
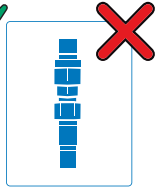
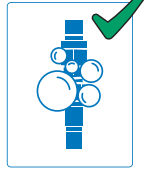



Parts List

Liste des pieces

Lista de piezas

Liste der Einzelteile



Legend | Légende | Leyenda | Legende

Legend	Légende	Leyenda	Legende
x - standard part	x - standard	x - estándar	x - standardteil
p - propane	p - propane	p - propano	p - propan
n - natural gas	n - gas naturel	n - gas natural	n - erdgas
ac - accessory	ac - accessoire	ac - accesorio	ac - zubehörteil
alt - alternate	alt - alternatif	alt - alternativa	alt - alternativ

	Part # Partie # Parte # Teil #	R365	R425	RB425	Description Description Descripción Beschreibung
1	N010-1750-BK	x			Lid Assembly
	N010-1751-BK		x		Assemblage du couvercle
	N010-1754-BK			x	Set de ensamblado de la tapa Deckelmontage
2	S91015	x	x	x	Temperature Gauge
	N685-0004K	x			Jauge de température Indicador de temperatura Temperaturanzeige
3	N385-0513-SER	x	x	x	Napoleon Logo Logo Napoléon Logo Napoleón Napoleon-Logo
4	N510-0013	x	x	x	Rectangular Bumper Pare-chocs rectangulaire Parachoques rectangular Rechteckiger Stoßfänger
5	S87014	x	x	x	Pivot Lid Couvercle pivotant Tapa pivotante Schwenckedel
6	N080-0413	x			Cross Light Bracket Support d'éclairage transversal Soporte de luz transversal Kreuzlichthalterung
7	N100-0060	x	x	x	Main Burner Tube Tube du brûleur principal Tubo del quemador principal Hauptbrennerrohr
7*	N100-0060-IL	alt	alt	alt	Main Burner Tube Tube du brûleur principal Tubo del quemador principal Hauptbrennerrohr
8	N305-0082	x	x	x	Sear Plate Plaque de cuisson Placa para dorar Anbratplatte
9	S87016	x			Cross Light Kit
	S87010		x	x	Kit de lumière transversale Kit de luz transversal Kreuzlicht-Bausatz
10	S87001	x	x	x	Sear Plate and Burner Kit Plaque de saisie et kit de brûleur Kit de quemador y placa de saltear Bausatz für Bratplatte und Brenner

	Part # Partie # Parte # Teil #	R365	R425	RB425	Description Description Descripción Beschreibung
11	N520-0055	x			Warming Rack Support de réchauffage
	N520-10001898		x	x	Rejilla de calentamiento Warmhaltegestell
12	S83015	x			Cast Iron Grids Grilles en fonte
	S83008		x	x	Rejillas de hierro fundido Gusseisen-Gitterroste
	S83016	ac			Stainless Steel Grids Grilles en acier inoxydable
	S83013		ac	ac	Rejillas de acero inoxidable Edelstahlgitter
13	N010-1030-SER	x			Casting Base Assembly Assemblage de la base de coulée
	N010-1041-SER		x		Conjunto de base de fundición Montage der Gussbasis
14	N200-0126-GY1SG	x			Base Back Cover Couvercle arrière de la base
	N200-0118-GY1SG		x	x	Tapa trasera de la base Basis Rückendeckel
15	N570-0145	x	x	x	Screw Vis Tornillo Schraube
16	N585-0145-GY1SG		x	x	Cart Heat Shield Bouclier thermique pour chariot
					Escudo térmico para el carro Wagen-Hitzeschild
17	N160-0033-GY1SG	x	x	x	Grease Tray Clip Clip pour bac à graisse
					Clip para bandeja de grasa Clip für Fettauffangschale
18	N710-0062	x	x	x	Grease Tray Bac à graisse
	62007				Bandeja de grasa Fettauffangwanne
19	N475-0442-GY1SG	x			Cart Panel Panneau du chariot
	N475-0363-GY1SG		x	x	Panel del carro Wagen-Panel
20	N530-0032	p	p	p	Propane regulator Régulateur de propane Regulador de propano Propanregler
	N530-0033	p	p	p	
	N530-0034	p	p	p	
	N530-0035	p	p	p	
	N530-0036	p	p	p	
	N530-0037	p	p	p	
	N530-0038	p	p	p	
	N530-0039	p	p	p	
	N530-0042	p	p	p	
	N530-0043	p	p	p	
	N530-0044	p	p	p	
	N530-0046	p	p	p	

	Part # Partie # Parte # Teil #	R365	R425	RB425	Description Description Descripción Beschreibung
21	N010-1149-SER			x	Cast Base Assembly Assemblage de base moulée Conjunto de base fundida Gussbasisbaugruppe
22	N240-0040			x	Electrode Électrode Electrodo Elektrode
23	N570-0104			x	Screw Vis Tornillo Schraube
24	N350-0087			x	Rear Burner Housing Boîtier du brûleur arrière Carcasa del quemador trasero Hinteres Brennergehäuse
25	N100-0058			x	Rear Burner Brûleur arrière Quemador trasero Hinterer Brenner
26	N720-0082			x	Flex Connector Connecteur flexible Conector flexible Flexibler Verbinder
27	N080-0364	x	x	x	Folding Shelf Bracket A Support d'étagère pliante A Soporte de estante plegable A Klappbare Regalhalterung A
28	N080-0365	x	x	x	Folding Shelf Bracket B Support d'étagère pliante B Soporte de estante plegable B Klappbare Regalhalterung B
29	N555-0097	x	x	x	Lighting Match Rod Tige d'allumage Varilla de fósforo Beleuchtung Streichholzstab
30	N710-0107	x			Drip Pan Bac d'égouttage
	N710-0094		x	x	Bandeja de goteo Auffangwanne
31	N080-0378-GY1SG	x	x	x	Door Pivot Bracket Support de pivotement de la porte Soporte pivote puerta Türzapfenhalterung
32	N590-0278-GY1SG	x			Cart Bottom Shelf Tablette inférieure du chariot
	N590-0292-GY1SG		x	x	Estante inferior del carro Unteres Wagenregal
33	N475-0607-GY1SG	x	x	x	Cart Panel Panneau de panier Panel del carrito Warenkorb-Panel
34	N510-0015	x	x	x	Caster Socket Socle de roulette Zócalo de ruedas Nachlaufsockel
35	N130-0015	x	x	x	Caster 3in Roulette de 3 pouces Rueda de 3 pulgadas Lenkrolle 3in
36	N370-0981CE	p	p	p	Tank Tray Kit Kit de plateau de réservoir Kit de bandeja de depósito Tankwannen-Bausatz
37	N010-1780-BK	x	x	x	Side Shelf Assembly Assemblage des tablettes latérales Montaje del estante lateral Montage der Seitenablage
38	S87015	x	x	x	Folding Shelf Kit Kit d'étagères pliantes Kit de estantería plegable Klappbarer Regal-Bausatz
39	N080-0380-GY1SG	x	x	x	Magnet Bracket Support magnétique Soporte Imán Magnet-Halterung
40	N010-0959-SER	x			Door Kit Assembly Assemblage du kit de porte
	N010-0869-BK-SER		x	x	Kit de montaje de la puerta Tür-Kit Montage
41	N325-0094-SER	x	x	x	Door Handle Poignée de porte Manija de la puerta Mit dem Handgriff
42	N105-0011	x	x	x	Door Bushing Prise de porte Casquillo de puerta Türsteckdose



	Part # Partie # Parte # Teil #	R365	R425	RB425	Description Description Descripción Beschreibung
43	N160-0023			x	Orifice Clip Retainer Clip retenedor de orificio Dispositif de retenue du clip de trou Öffnungscliphalter
44	N345-0023			x	Hose Tuyau Manguera Schlauch
45	Z255-0002-1			x	Side Burner Fitting Assembly Assemblage du raccord du brûleur latéral Montaje del quemador lateral Seitliche Brennerarmatur
46	N105-0017			x	Side Burner Hose Bushing Douille de tuyau de brûleur latéral Casquillo de la manguera del quemador lateral Schlauchbuchse für Seitenbrenner
47	N750-0016			x	Electrode Lead Wire Fil conducteur de l'électrode Cable de electrodo Elektrodendraht
48	N720-0079			x	Flex Tube Tube flexible Tubo flexible! Flex-Rohr
49	N455-0091			p	Orifice Orifical Orificio Blende
	N455-0058			p	Orifice - DE - Pressure 30 vs 50 Orifice - DE - Pression 30 vs 50 Orificio - DE - Presión 30 vs 50 Öffnung - DE - Druck 30 vs. 50
50	N010-1222-SER			x	Shelf Assembly Assemblage des étagères Montaje de estantes Montage des Regals
51	Z580-0003			x	Pivot Lid Couvercle pivotant Tapa pivotante Deckel-Drehpunkt
52	Z430-0002			x	Lid Magnet Aimant pour le couvercle Imán de tapa Magnet im Deckel
53	Z305-0008			x	Side Burner Grate Grille du brûleur latéral Rejilla lateral del quemador Seitenbrenner-Rost
54	N100-0070			x	Side Burner Flame Flamme du brûleur latéral Llama del quemador lateral Seitenbrenner Flamme
55	N335-0099-BK1HR			x	Side Burner Lid Couvercle du brûleur latéral Tapa del quemador lateral Seitenbrenner-Deckel
56	Z325-0013			x	Lid Handle Manche du couvercle Mango de la tapa Griff des Deckels
57	N010-1760-30-BK	x			Control Panel Assembly Assemblage du panneau de contrôle Ensamblaje del panel de control Montage des Bedienfelds
	N010-1761-30-BK		x		
	N010-1761-50-BK		x		
	N010-1762-30-BK			x	
	N010-1762-50-BK			x	
58	S86002			x	Igniter Allumeur Encendedor Zünder
	S86003			x	
59	N380-0044			x	Small Control Knob Petite bouton de commande Mando de control pequeño Kleiner Bedienknopf





	Part # Partie # Parte # Teil #	R365	R425	RB425	Description Description Descripción Beschreibung
60	N255-0027	x	x	x	Union Fitting Raccord union Accesorio de unión Verschraubung
61	N380-0043	x	x	x	Control Knob Bouton de commande Mando de control Bedienknopf
62	N160-0053	x	x	x	Flex Line Clip Clip pour ligne flexible Clip de línea flexible Flex-Line-Klemme
63	N720-0044	x	x	x	Connector Connecteur Conector Anschluss
64	N385-10001896-SER	x	x	x	Rogue Logo Logo Rogue Logotipo Rogue Rogue Logo

*Alternate burner for Israel.

*Brûleur alternatif pour Israël.

*Quemador alternativo para Israel.

*Alternativer Brenner für Israel.

Accessories Parts List

Liste des pièces accessoires

Lista de piezas de accesorios

Zubehör Teilleiste

Part # Partie # Parte #	R365	R425	RB425	Description Description Descripción
N590-0261	ac	ac	ac	Condiment Tray Plateau à condiments Bandeja de condimentos Gewürztablett
62050	ac	ac	ac	Kit, Maintenance Jetfire Brush/Burner Kit Kit de maintenance Jetfire (brosse/burner kit) Kit, Mantenimiento Jetfire Cepillo/ Quemador
69912 CE	ac	ac	ac	Rotisserie kit Kit de rôtisserie Kit de asador Rotisserie-Set
69913 GB	ac	ac	ac	Rotisserie kit Kit de rôtisserie Kit de asador Rotisserie-Set
69915 IL	ac	ac	ac	Rotisserie kit Kit de rôtisserie Kit de asador Rotisserie-Set
61365	ac			Cover, Grill Couvercle, grill Tapa, Parrilla
61427		ac	ac	Cover, Grill Couvercle, grill Tapa, Parrilla
56365	ac			Griddle, Cast Iron Gril en fonte Plancha, Hierro Fundido
56425		ac	ac	Griddle, Cast Iron Gril en fonte Plancha, Hierro Fundido
67732	ac	ac	ac	Charcoal/smoker tray Bac à charbon/fumoir Bandeja Carbón Ahumador
62007	ac	ac	ac	Grease Trays Bacs à graisse Bandejas para Grasas
S82002	ac	ac	ac	Premium Caster/Plug Kit Kit de roulettes et de bouchons Premium Kit de ruedas y clavijas Premium



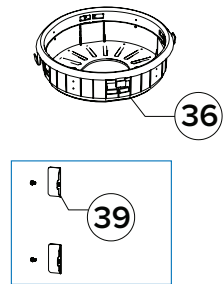
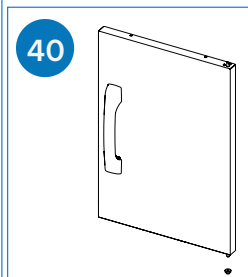
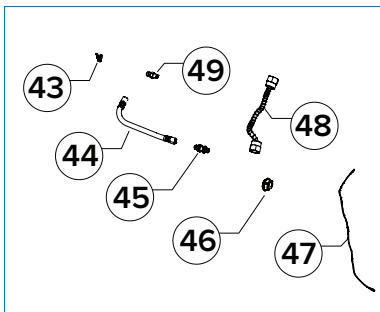
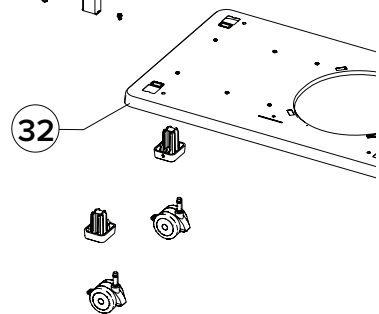
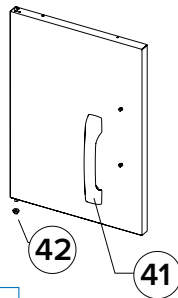
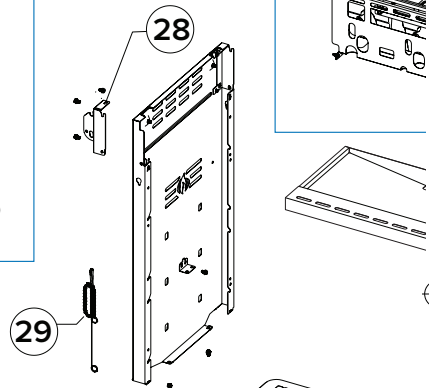
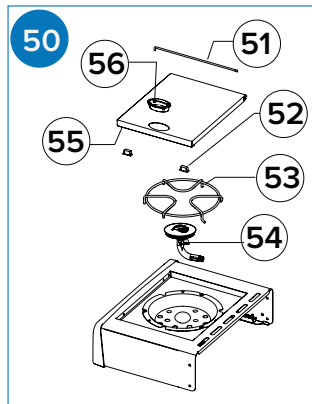
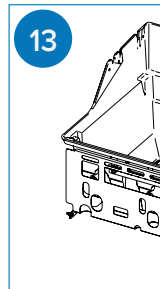
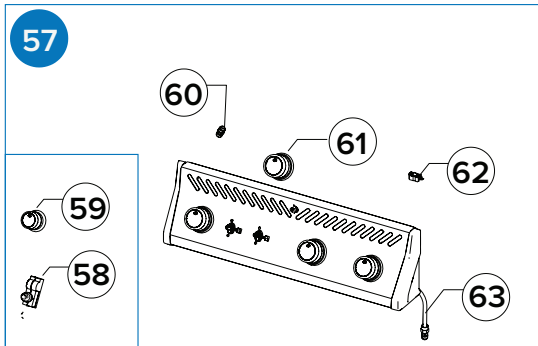
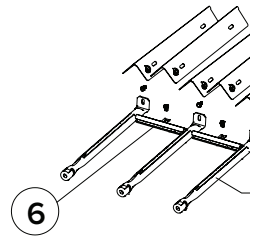
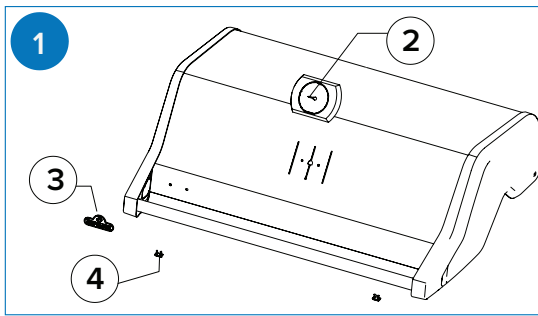

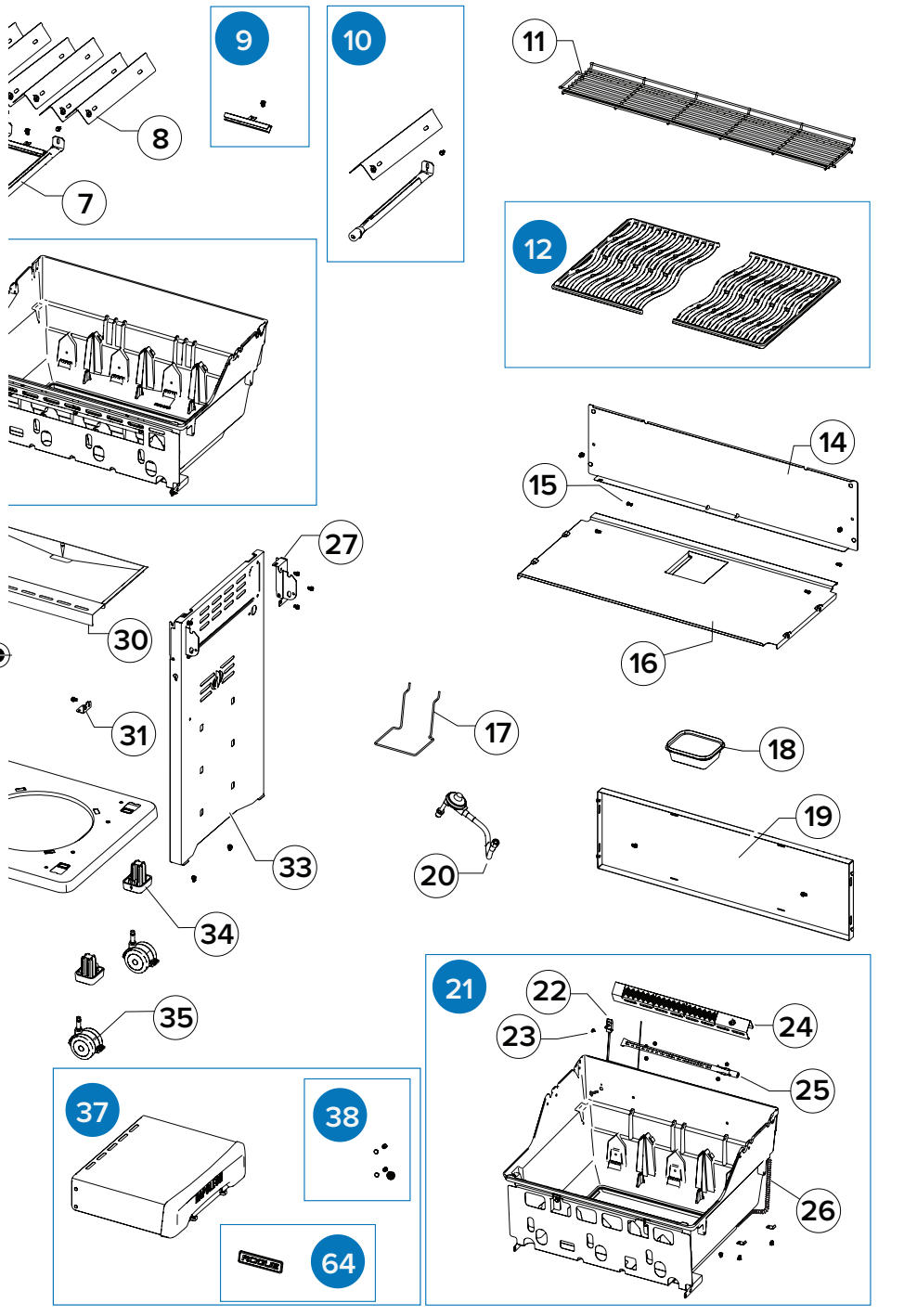

NAPOLEON®

Celebrating over 40 years
delivering home comfort products

Célébrant plus de 40 ans
de produits de confort pour la maison

Celebrando más de 40 años
entregando productos de confort para el hogar

Wir feiern über 40 Jahre
Lieferung von Produkten für den Wohnkomfort



NAPOLEON® products are protected by one or more U.S. and Canadian and/or foreign patents or patents pending.

Les produits de NAPOLEON® sont protégés par un ou plusieurs brevets américains, canadiens et/ou étrangers au par des brevets en instance.

Los productos NAPOLEON® están protegidos por una o más patentes o patentes pendientes en E.U., Canadá y/u otros países.

NAPOLEON®-Produkte sind durch ein oder mehrere US-amerikanische und kanadische und/oder ausländische Patente oder angemeldete Patente geschützt.



**Address | Adresse
Dirección | Adresse**

Wolf Steel Ltd.

De Riemsdijk 22, 4004 LC, Tiel,
The Netherlands

10-12 Home Farm,
Meriden Road, Berkswell,
CV7 7SL, United Kingdom

24 Napoleon Road, Barrie, Ontario,
L4M 0G8, Canada



**Phone | Téléphone
Teléfono | Telefon**

Europe

+31 345 588655

**Online | En ligne
En línea | On-line**

 eu.info@napoleon.com

 www.napoleon.com